

Cutaway view of rectangular DuraDuct™ UCR

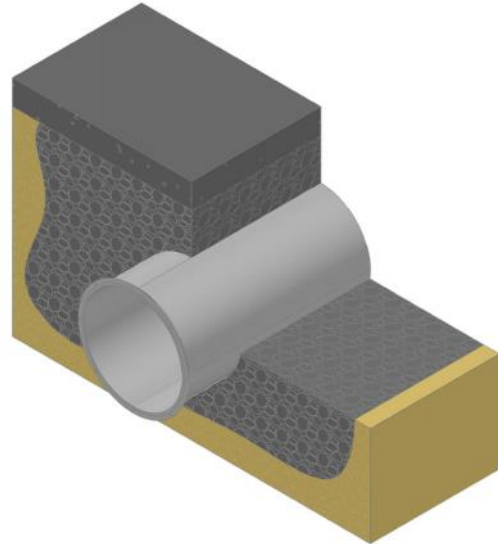

Cutaway view of round DuraDuct™ UCR

DuraDuct™ UCR

Underground Corrosion Resistant Duct

DuraDuct™ UCR is a stainless steel underground duct system that is designed to provide superior structural strength and integrity in a variety of harsh underground environments. Available in both round and rectangular cross sections, the UCR system uses a proven liquid and air tight bolted joint connection, helping to reduce installation time, and does not require any additional reinforcing or supports, the bane of most underground duct systems.

The DuraDuct™ UCR duct assembly is shipped to site with fully welded and tested seams, ensuring a leak free Installation. With a smooth inner surface allowing for effective air movement and available in lengths up to 10 feet, DuraDuct UCR is your answer when looking for a quick, easy, and cost effective installation.

DuraSystems offers a comprehensive selection of fittings and configurations to suit your project's needs.

DuraDuct™ UCR is a unique pre-fabricated underground duct system that is ideal for corrosive environments.

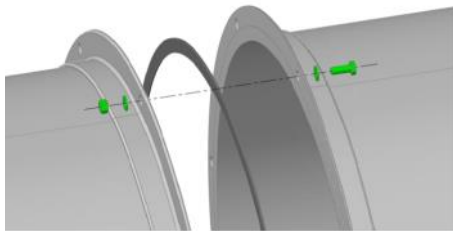

With a fully customizable design, DuraDuct™ UCR is engineered to the specific requirements of each project. The unique design of the DuraDuct™ UCR system can eliminate the requirement for concrete encasement of the ductwork and reduces the excavation and backfill required.

Please visit our website at www.durasystems.com to find your local representative or contact DuraSystems for further information at info@durasystems.com.